

Fristam FDS



The Fristam FDS double-screw pump

By developing this exceptional pump, we intended to set new standards in double-screw technology. We started by re-thinking the technical and functional principles of this highly sophisticated type of pump from the ground up. We continued by thoroughly analysing each and every component, refining the design until we had perfected its every aspect and every functionality.

We have eliminated the previously known deficiencies of this technology and optimised key aspects such as smooth running, temperature stability, maintenance and repair. Consequently, we can offer you a unique product that has been refined down to the most minute detail.

The Fristam FDS combines all the advantages of double-screw technology with our company's traditionally high quality standards. It is suitable for a wide range of applications and offers maximum flexibility.

This very special positive displacement pump is ideal for the most viscous products. At the same time, it is capable of reaching higher speeds of up to 3,600 min⁻¹. Consequently, it can transport significant amounts of any low-viscosity medium, for example water or detergent solution. This renders the use of an additional pump for cleaning processes obsolete. The Fristam FDS can handle extreme viscosities as well as the highest loads effortlessly and easily copes with high differential pressures without overheating.

Its axial transportation principle results in very low pulsation even in the highest pressure ranges. In addition, the FDS ensures superior hygiene as its mechanical seals are positioned in fully flushed areas with constant pressure conditions. Because there are no cavities, there is no residue when flushing the pump in CIP. Our latest model is not only fully hygienic, but can also be sterilised.

Thanks to its compact size and specially designed bearings the Fristam FDS can be mounted horizontally as well as vertically. Inspection and maintenance have never been as simple as this: seals and conveying elements can be exchanged easily and quickly. The use of high-quality materials combined with Fristam's usual solid workmanship ensures superior reliability.



A concept fully explored

AMAZING VERSATILITY

Fristam FDS pumps can be used in the most diverse and challenging applications with great success.

Their smart design enables us to address each and every customer requirement and perfectly adapt the FDS to any specific application, fulfilling almost any client wish.

Fristam FDS pumps are capable of transporting an impressive range of products gently and with maximum efficiency:

- From the highest to lowest viscosities – even non-flowing goods and products with air pockets
- At the lowest and highest temperatures – also in extremely hot applications
- Handling even very low NPSH_A conditions
- Almost pulsation-free
- With high energetic and volumetric efficiency
- With contact-free feed screws, i.e. avoiding any contamination of the product

The Fristam FDS is capable of evacuating up to the physical limits and of building up an impressive differential pressure.



MECHANICAL SEALS

The FDS' mechanical seals are fully immersed in the flowing medium. Their smart layout ensures improved protection from leakages with both single- and double-acting seals.

The semi-cartridge principle, in com-

ination with the clever design of the pump casing in three segments, make mounting and replacing seals simpler than ever. If needed, they can be removed and loaded through the front with just a few quick and easy steps.

SOPHISTICATED CASING

The three-piece pump casing of the Fristam FDS consists of an intermediate flange, the screw casing and the pump cover. This layout allows previously unimaginable flexibility when it comes to connection types and

individual adaptation to system requirements. Furthermore, it is specifically configured for easy access and maintenance. The FDS offers maximum efficiency with extremely tight internal clearances.

SEAMLESS SEAL CHANGEOVER

The FDS' pump casing, cover and the two screws can be removed in just a few simple steps.

After unlocking the item keys that secure the mechanical seals in place, they can be removed and replaced easily and quickly from the front of the pump.

The entire procedure requires only a few moments and can be carried out without great technical effort.



1. Removal of pump casing and cover



2. Removal of screws



3. Unlocking of item keys



4. Exchange of mechanical seals



MAXIMUM FLEXIBILITY

With its wide range of feed screws featuring various pitch, the Fristam FDS offers maximum flexibility. This pump is suitable for a great range of applications and capable of meeting the most diverse requirements as

well as the highest standards. Furthermore, its well thought-through design opens up previously unimagined freedom with many possibilities for mounting as well as easy access and maintenance.

Choosing feed screws

Deciding on the perfect pitch is the key to successful operation of the double-screw pump. The following criteria are crucial:

- The differential pressure (inversely proportional to the dimensions of the pitch)
- The volumetric flow rate (directly proportional to the dimensions of the pitch)
- Particles and/or solid substances in the transported material (here the screw profile and the size of the pump chamber must be considered as well)
- The sensitivity to shearing of the transported material

The smaller the pitch, the lower the NPSH_A values will be.



ESPECIALLY SOLID SHAFT

When constructing the shaft, we specifically focused on adding strength in the area of its critical diameter. This ensures maximum rigidity even under the most difficult conditions

and results in an especially smooth run, along with lower operating temperatures also under elevated pressure. Ultimately, it expands the FDS' lifespan significantly.

OPTIMISED BEARINGS SUPPORT

The combination of particularly large bearings and an increased bearing distance result in impressive stability and superior rigidity even with high axial forces and extreme rotation

speeds. The central positioning of the gearwheels makes the FDS a compact design. Its construction is laid out for optimised lubrication and oil circulation. Consequently,

the bearings are always immersed in an optimised quantity of oil flowing along a specifically designed circulation path, which ensures a significantly longer service life.

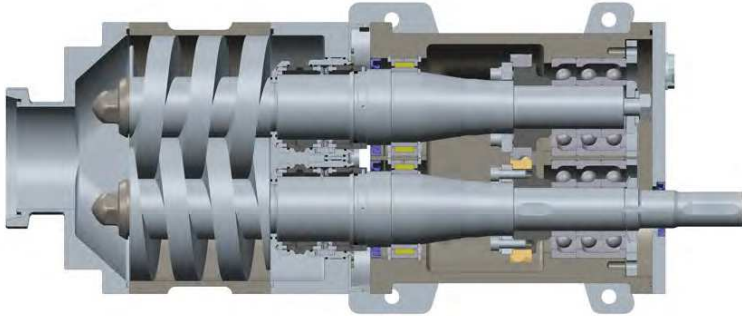

SOPHISTICATED GEARBOX

When designing the gearbox, we put a special emphasis on creating a smart yet hands-on layout. Access to the synchromesh gear is facilitated through a cover that can be removed easily with just a few turns of a screw. The pump can be kept in its position, and even moving the drive becomes unnecessary.

Owing to its specially designed bearings, the FDS offers previously unimagined simplicity with regard to all gear-related maintenance procedures.



360° MOUNTING

The FDS series can be mounted horizontally as well as vertically.

Combined with the pump's independent direction of rotation, this ensures perfect flexibility when it comes to installation.

TECHNICAL DETAILS OF THE FRISTAM FDS SERIES

Model	FDS 1	FDS 2	FDS 3	FDS 4
Max. discharge pressure [bar]	20	25	25	25
Maximum flow rate [m³/h]	20	40	100	180
Max. rotation speed [min ⁻¹]	3,600	3,600	3,600	3,000
Connection DN	15 – 50	40 – 80	65 – 100	80 – 150
Connection types	To suit requirements			
Viscosity	Up to 1,000,000 mPas			
Rotation	Reversible			
Temperatures	Up to 150°C (standard), 220°C with special versions			
Gasket materials	HNBR, EPDM, FKM, FFKM, alternative materials possible			
Mounting	Horizontal (standard), vertical and sideways optional			
Mechanical seals	Single and double (flushed or pressurized)			
Feed screws (standard and extended)	6	8	9	8
Max. free ball passage [mm]	18 (26)	26 (36)	32 (48)	41 (57)
Options	High-pressure variants, ATEX, heated jacket, special surface treatments, electropolishing, rectangular leads, bespoke adaptations to specific products, processes and systems			

Please note that all technical information is subject to further development of the product range.

THE FRISTAM FDS AT A GLANCE

- For extremely high and low viscosities
- For low and elevated temperatures
- Gentle product handling
- Low pulsation
- Incredible pressure and suction capabilities
- Compact
- Long-lasting
- Abrasion-free
- Maximum hygiene including aseptic
- For production and CIP
- Maximum application flexibility
- Horizontal and vertical mounting
- Easy maintenance and repair
- High efficiency

SAMPLE APPLICATION

	Product	CIP
Medium	Concentrate (whey, fruit)	Detergent, water
Viscosity	200 – 1,000 mPas	1 mPas
Flow rates	6 m³/h	18 m³/h
Differential pressure	8 – 10 bar	2 bar
Temperature	5 – 30°C	85°C
Shaft power	2.8 – 3.5 kW	3 kW
rpm	650 – 750 min ⁻¹	1,800 min ⁻¹
Motor frequency	34 – 40 Hz	95 Hz

Pump: FDS 2,3 with six-pole 5.5 kW three-phase motor

CHARACTERISTIC CURVES

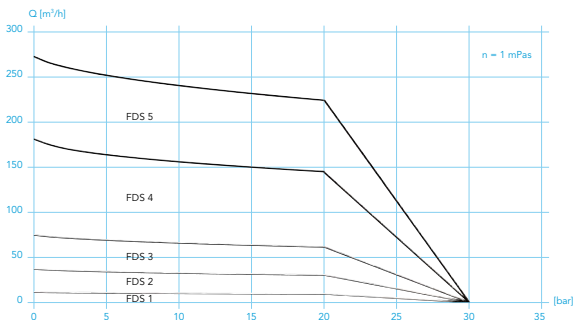



Fristam Pumpen KG (GmbH & Co.)
P.O. Box 80 08 80
21008 Hamburg Germany

Phone +49 (0)40 725 560
Fax +49 (0)40 7255 6166
Email info@fristam.de

For international contact
information, please
visit www.fristam.de.

Fristam
PUMPS